

1932R

ELECTRIC SCISSOR LIFT

JLG
reachingout®

Performance

Platform Height–Elevated	5.8 m
Platform Capacity	230 kg
Capacity on Platform Extension	120 kg
Lift/Lower Time	25/26 seconds
Maximum Drive Height	Fully Elevated
Weight*	1,590 kg
Drive Speed–Elevated	0.8 km/h
Drive Speed–Lowered	3.2 km/h
Gradeability	25%
Turning Radius (Inside)	Zero
Turning Radius (Outside)	1.60 m

* Certain options or country standards will increase weight.

Standard Specifications

Power Source

Batteries	4 x 6V 220 amp-hr
Charger	20 amp (Universal Algorithm)
Drive	Hydraulic Front-wheel

Hydraulic Reservoir

- Capacity 17 L
- Pump Fixed Displacement Gear

Tyres

- Tyre Size/Type (Non-Marking) 323 x 100 mm

Brakes

- Multi-Disc Friction

Standard Features

- Proportional Controls
- Battery Condition Indicator
- All Motion Alarm
- 20 Amp Automatic SCR Charger
- Horn
- Hourmeter
- Tilt Alarm and Light
- Lanyard Attach Points
- Movable, Removable Platform Control
- Nickel Plated Pins
- Lubrication Free Scissor Arm Bushings
- Scissor Maintenance Prop
- Active Pothole Protection System
- Lifting and Tie Down Points
- Fork Lift Pockets
- 86 cm Foot-Actuated Deck Extension
- Steel Swing-Out Doors
- Variable Tilt Window
- Manual Descent Cable
- Diamond Tread Steel Deck
- Greaseless Kingpin Joints
- Analyzer Port for Diagnostics
- Dynamic Braking
- Flashing Amber Beacon
- Self-Closing, Self-Latching Gate

Accessories & Options

- 220 Amp-Hour AGM Batteries
- MDI (Ground)
- Anti-Vandalism Package for Ground Controls and Platform Controls
- Ambient Noise Alarm
- AC Outlet To Platform incl. ELCB



1932R

ELECTRIC SCISSOR LIFT



Dimensions

All dimensions are approximate.

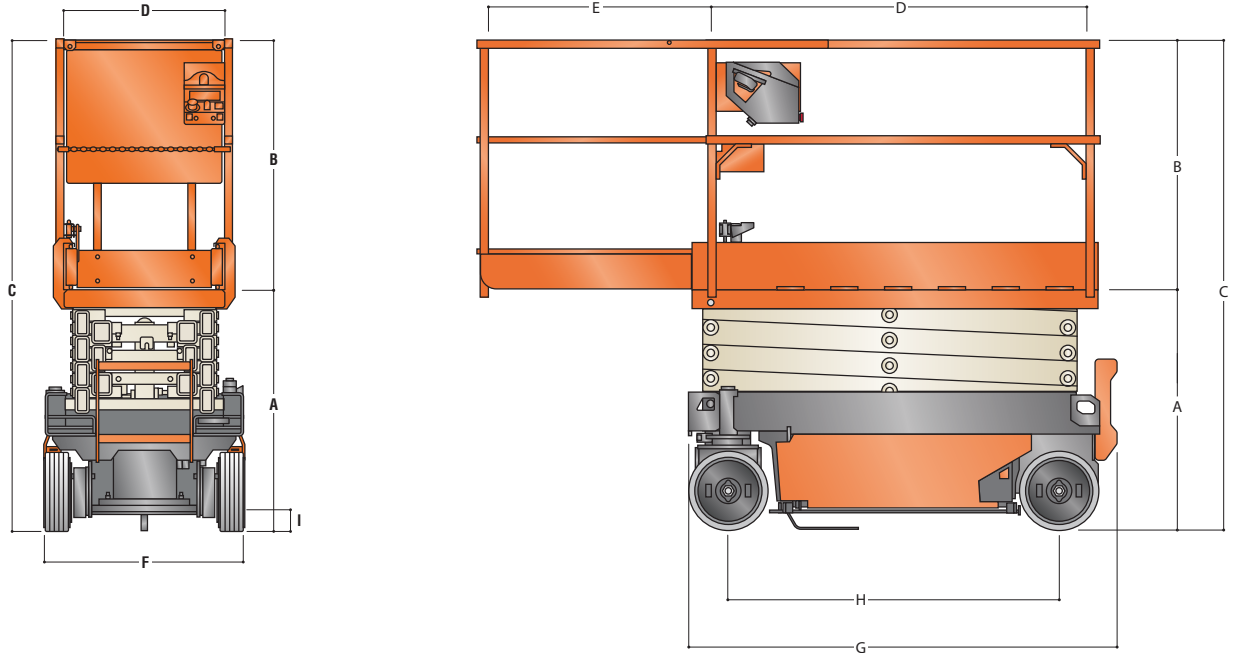

A. Platform Height—Lowered	0.98 m
B. Platform Railing Height	1.02 m
C. Overall Height	2.00 m
D. Platform Size	0.64 m x 1.59 m
E. Platform Extension	0.86 m

F. Overall Width	0.82 m
G. Overall Length	1.74 m
H. Wheelbase	1.34 m
I. Ground Clearance	0.07 m



The JLG "1 & 5" Warranty

JLG Industries, Inc. backs its products with its exclusive "1 & 5" Warranty. We provide coverage on all products for one (1) full year and cover all specified major structural components for five (5) years. Due to continuous product improvements, we reserve the right to make specification and/or equipment changes without prior notification. This machine meets or exceeds AS/NZS 1418.10 2011 as originally manufactured for intended applications.

JLG Industries (Australia)

358 Park Road
Regents Park, NSW 2143
Telephone 02 8718 6300
Fax 02 8718 6377

www.jlg.com.au

An Oshkosh Corporation Company