

600 HC3 SERIES

TELESCOPIC HI-CAPACITY BOOM LIFTS



Performance

Platform Height		
600S HC3	59 ft 8 in.	18.18 m
660SJ HC3	65 ft 8 in.	20.02 m
Horizontal Outreach		
600S HC3	50 ft 2 in.	15.29 m
660SJ HC3	57 ft 1 in.	17.40 m
Swing	360° Continuous	
Platform Capacity		
600S HC3 - Restricted	750/1000 lb	340/454 kg
600S HC3 - Unrestricted	660 lb	300 kg
660SJ HC3 - Restricted	750/1000 lb	340/454 kg
660SJ HC3 - Unrestricted	660 lb	300 kg
Platform Rotator		
600S HC3	160° Hydraulic	
660SJ HC3	180° Hydraulic	
Weight ¹		
600S HC3	22,900 lb	10,387 kg
660SJ HC3	29,281 lb	13,281 kg
Max. Ground Bearing Pressure		
600S HC3	88 psi	6.19 kg/cm ²
660SJ HC3	110 psi	7.73 kg/cm ²
Drive Speed 4WD	3.8 mph	6.1 km/hr
Gradeability 4WD	45%	
Tilt Cut Out	5°	
Axle Oscillation	8 in.	0.2 m
Turning Radius, Inside/Outside 2WS		
	9 ft 7in./19 ft 4 in.	2.92 m/5.89 m

1. Certain options or country standards increase weight

Standard Specifications

Power Source

Dual Fuel Engine		
Ford MSG425-DF	84 hp	62 kW
Diesel Engine		
Deutz D2.9L4 Tier 4 Final	48.8 hp	36.4 kW
Fuel Tank Capacity	31 gal	117 L

Hydraulic System

Capacity	34 gal	129 L
Auxiliary Power	12V DC	

Tires

Standard	355/55D625 Foam Filled	
Optional	Non Marking Foam-Filled	



3 Capacity Zones - Each rated for 3 occupants + tools/materials

HC3

Standard Features

- Oscillating Axle
- Hydraulic Platform Rotator
- 110V AC Receptacle in the Platform
- 5 Degree Tilt Alarm/Indicator Light
- Swing-Out Engine Tray
- 12V DC Auxiliary Power
- Hourmeter
- SkyGuard SkyLine™
- Control ADE® System
- All Motion Alarm
- Proportional Controls
- Gull-Wing Hoods
- Platform Console Machine Status Light Panel; Interactive Display at Ground Controls*
- Engine Distress Warning/Shutdown—Selectable via JLG Analyzer
- Lifting/Tie Down Lugs
- Load Sensing System

*Provides indicator lights at platform control console for envelope zone base on platform load, system distress, fuel level, low fuel, 5 degree tilt light and foot switch status.

Accessories & Options

- 36 x 72 in. (0.91 x 1.83 m) Platform
- Fall Arrest Platform
- Inward Swinging Gate
- Soft Touch System
- Bolt On External Fall Arrest
- SS Mesh to Top Rail
- White Noise Alarm
- Pipe Racks
- Battery Disconnect
- Top Rail Extension
- SkySense™
- Operators Tool Tray
- Tow Package
- 43.5 lb (19.7 kg) Propane Tank
- Cold Weather Start Kit¹
- Hostile Environment Kit²
- Light Package³
- Flashing Amber Beacon
- Arctic Package⁴
- Accessory Packages:
 - SkyWelder®
 - SkyPower®
 - SkyGlazier

1. Includes battery blanket, hydraulic tank heater, block heater.

2. Includes boom wipers, cylinder bellows and console cover.

3. Includes platform work lights, head and tail lights, amber beacon.

4. Includes arctic hydraulic hoses (drive, steer), main boom cable, extreme cold engine oil, fuel conditioner, engine block heater, battery blanket, glow plugs, hydraulic tank heater, oversized footswitch and arctic hydraulic oil.

Additional accessories and options available via JLG Aftermarket.

600 HC3 SERIES

TELESCOPIC HI-CAPACITY BOOM LIFTS



Dimensions

All dimensions are approximate.

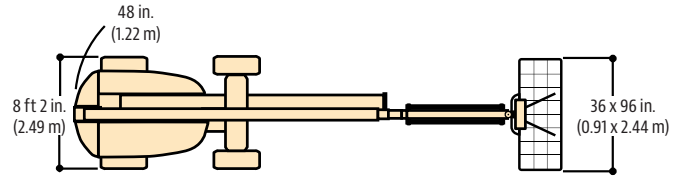
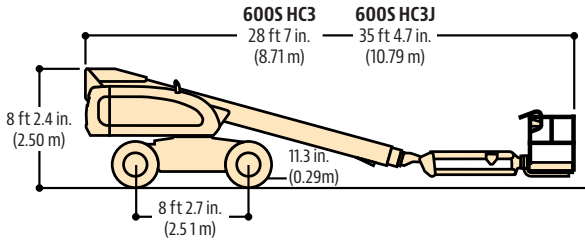

Reach Dimensions

600S HC3

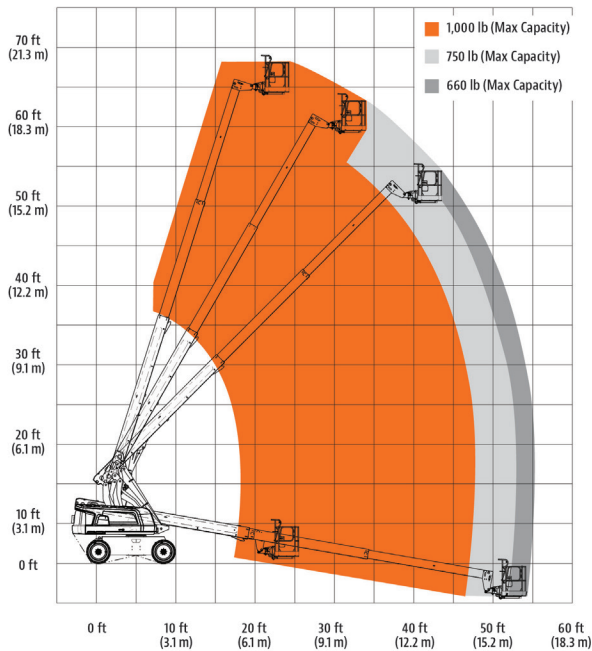

660SJ HC3

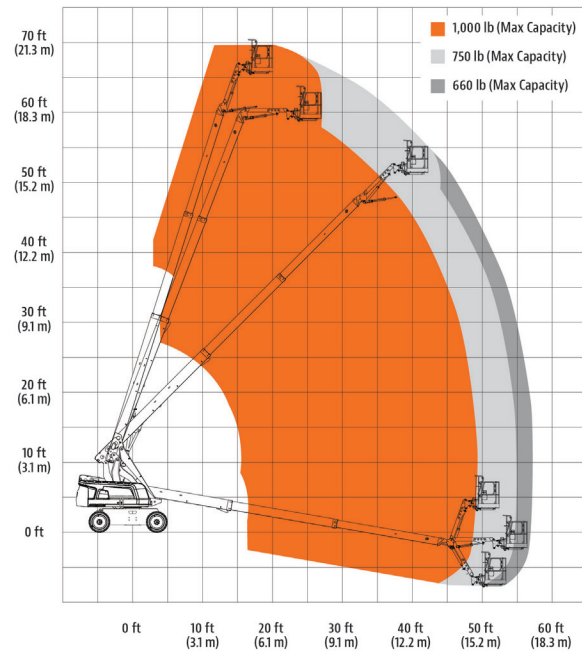

The JLG "1 & 5" Warranty

We provide coverage for one (1) full year and cover all specified major structural components for five (5) years. Due to continuous product improvements, we reserve the right to make specification and/or equipment changes without prior notification. This machine meets or exceeds applicable ANSI and CSA requirements based on machine configuration as originally manufactured for intended applications. Please reference the serial number plate on the machine for additional information.

Part No.: 3131034
R012220
Printed in USA

JLG Industries, Inc.
1 JLG Drive
McConnellsburg, PA 17233-9533
Telephone 717-485-5161
Toll-free in US 877-JLG-LIFT
Fax 717-485-6417
www.jlg.com

An Oshkosh Corporation Company