

TURBOFARMER II TF42.7TGS-140 PTO

- ▶ Fuel efficient **Duetz Tier IV Final Engine**
- ▶ Low centre of gravity and an even weight distribution allow **excellent stability**
- ▶ **Mechanical PTO** 540/1000 speeds, with selector in the cabin
- ▶ Improved boom layout allows greater **360 degree visibility**

SINCE 1964



Merlo's all-new **Turbofarmer II** leads the pack in precision and technology.



TURBOFARMER II

TF42.7TTCS-140 PTO

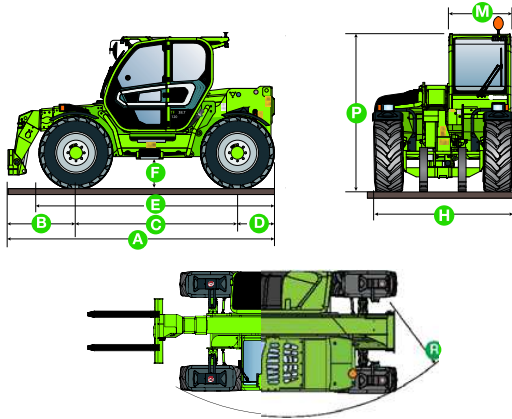

DIMENSIONS

A (mm)	5,020
B (mm)	1,075
C (mm)	2,800
D (mm)	645
E (mm)	3,980
F (mm)	460
H (mm)	2,250
M (mm)	995
P (mm)	2,550
R (mm)	3,985

PERFORMANCE

Unladen Weight (kg)	7,900
Maximum Load Capacity (kg)	4,000
Maximum Lift Height (m)	7.2
Capacity at Maximum Height (kg)	4,000
Maximum Reach (m)	3.8
Capacity at Maximum Reach (kg)	1,400
Boom Side Shift	±150
Frame Levelling	±10

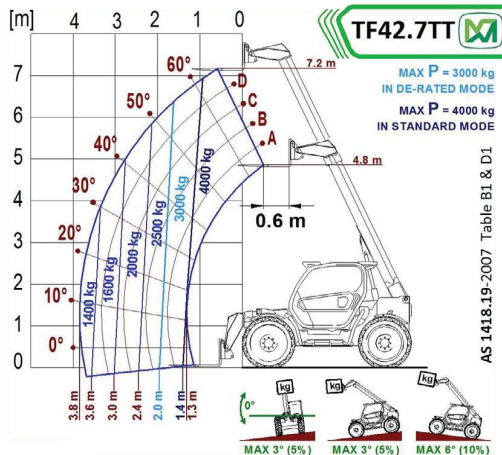

STANDARD SPECIFICATIONS

Engine	
Turbo Engine	Duetz TCD3.6 Euro IV
Range/Cylinders	3600/4
Engine Power (kW/HP)	100/136
Maximum Speed (km/h)	40
Fuel Tank Capacity (l)	140

Transmission	
Hydrostatic Merlo EPD Transmission	Std
Speeds	2
Dual Reverse Shuttle System	Std
Pedal Inching-Control	Std
Permanent Four-Wheel Drive	Std

Brakes	
Automatic Parking Brake	Std
External Dry Disc Service Brakes	Std

Tyres	
Standard Tyres	405/70-24

Cab	
Cab Suspension	Std
Air Conditioned Cabin	Std
Pressurized Cabin	Std
Air Suspension Seat	Std
FOPS (ISO 3449) and ROPS (ISO 3471) Cab	Std

Steering	
All Wheel Steering	Std

Instruments	
Electronic Joystick Control	Std
Merlo Dynamic Load Control (M-CDC)	Std
Reversing Camera	Std

Hydraulic System-Implement	
Load-Sensing Hydraulic System (bar-l/min)	210-150
BSS Hydro-Pneumatic Boom Suspension	Std
Hydraulic Oil Tank Capacity (l)	110
Fan Drive Pump (l/min)	46
Auxiliary Hydraulic Service on Boom	Std

Accessories and Attachments	
Tac-Lock Attachment Locking	Std
Standard Forks	Std
Fork Extensions	Optional
Digging Bucket	Optional
Re-Handling Bucket	Optional
4 x 1 Bucket	Optional
Multipurpose Bucket with Grab	Optional
Crane Hook	Optional
Reduced Height Crane Jib	Optional
Drum Clamp	Optional
Forks with Slide Protection	Optional
Handler for Single Round Bale	Optional
Fork Rotator	Optional
Carriage with Floating Forks	Optional

EXTRA SPECIFICATIONS

Mechanical PTO (540/1000)	Std
Frame Levelling	Std
Boom Side Shift	Std
Multi Position Tow Hook	Std
Hydraulic Reversible Fan	Std
Rear Hydraulic Auxillary Lines	2 Sets



120-124 Toongabbie Road Girraween 2145 NSW Australia
For further information please call 1300 657 325 or visit merloaustralia.com.au

Merlo reserves the right to modify and update the contents of this document at any time. Information and technical data are as available at time of printing.

For current information on Merlo products please contact your Merlo dealer.

ABN 87116110751 **MER-TF42.7TTCS-140PTO-2018**